











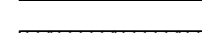

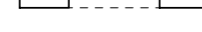



SIGNATURFORKLARING:

-  Betonelement iht. ING.
-  Betonsandwichelement iht. ING.
-  -205.C01 - Væg af porebeton 50, 75, 100 og 200mm, iht. bygningsdelsbeskrivelse
-  Betonoverligger / hulmål iht. ING.
-  205.F01 - Væg af gipsplade, iht. bygningsdelsbeskrivelse -
-  205.F01 - Væg af gitternet, iht. bygningsdelsbeskrivelse -
-  -205.F01 Rørkasser af gipsplade, kontur af overliggende rørkasser iht. bygningsdelsbeskrivelse
-  -205.C01 - Væg af porebeton 260mm, iht. bygningsdelsbeskrivelse
-  Affaldsskakt, indkast Cc. 1100 mm fra FG gulv
-  -205.B02 Røglern / serviceadgang, iht. bygningsdelsbeskrivelse
-  (TA) Kontur af overliggende overlys / installationer
-  Installationskakt
-  DT Angiver dørteleton
-  AN Angiver altannedløb
-  SR Angiver stigrer
-  SV Angiver vandfyldt slangevinde
-  Primær adgangsvej

NOTE:
 Alle mål er i mm.
 Indretning og målsætning af badekabiner, se bygningsdelstegning.
 Indretning og målsætning af køkkener, se bygningsdelstegning.

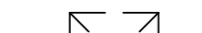
Tegn. nr. **1.177** Rev. **4**

HAVNEVIGEN

NCC SAGSNAVN: ISTARNP
 NCC SAGSNR.: 29330117

BYGHERRE:
NCC NCC Bolig A/S
 Østmarken 3B, 2860 Søborg

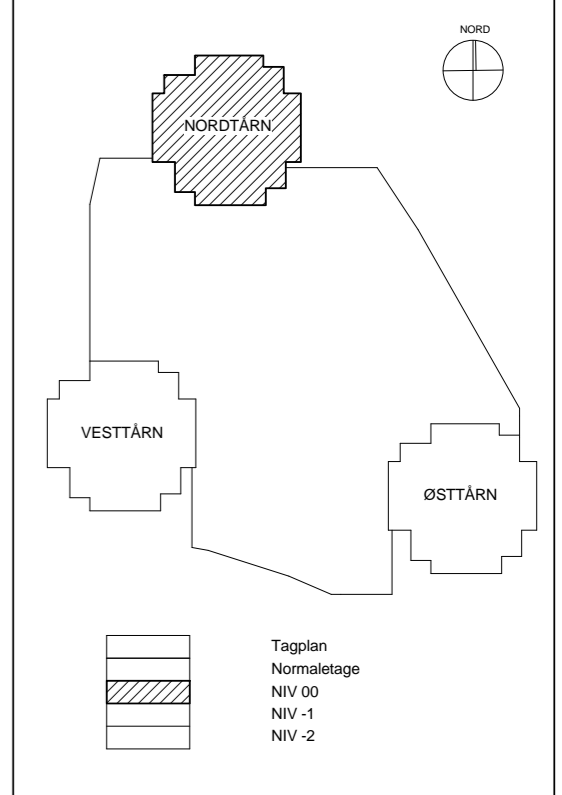

Rev	Rev. dato	Revisionen omfatter	Udf	Kontr
4	26.02.2014	Nr. p+depoter, iso. i kældere, pedelrum, terrasser	ESCH	
3	20.09.2013	Se rettelssesky + døre "tagget"	ESCH	
2	23.05.2013	Badekabine B tilrettet, se rev. sky	ESCH	
1	14.05.2013	Se rettelssesky	ESCH	

Emne:
NIV 00 - Nordtårn, Stueplan

Mål: 1 : 100 Sags. nr.: 12014
 Datum: 08.05.2013
 Udf : ESCH Kontr : JOJ Godk. : JOJ Format : A2
 Fil : Fase : Hovedprojekt

- NCC** TOTALENTREPRENØR
 NCC Construction Danmark A/S
 Østmarken 3B, 2860 Søborg
- ARKITEKT ARKITEMA ARCHITECTS
 - LAND.ARKITEKT SCHØNHERR A/S
 - KONSTRUKTION NCC Konstruktion Danmark A/S
 - VVS-INSTAL. NCC Konstruktion Danmark A/S
 - EL-INSTAL. NCC Konstruktion Danmark A/S