











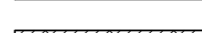

**SIGNATURFORKLARING:**

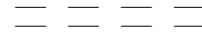
-  Betonelement iht. ING.
-  Betonsandwichelement iht. ING.
-  -205.C01 - Væg af porebeton 50, 75, 100 og 200mm, iht. bygningsdelsbeskrivelse
-  Betonoverfliger / hulmål iht. ING.
-  205.F01 - Væg af gipsplade, iht. bygningsdelsbeskrivelse -
-  205.F01 - Væg af gitternet, iht. bygningsdelsbeskrivelse -
-  -205.F01 Rørkasser af gipsplade, kontor af ovenliggende rørkasser iht. bygningsdelsbeskrivelse
-  -205.C01 - Væg af porebeton 260mm, iht. bygningsdelsbeskrivelse
-  Affaldsskakt, indkast Cc. 1100 mm fra FG gulv
-  -205.B02 Røglem / serviceadgang, iht. bygningsdelsbeskrivelse
-  (TA) Kontur af ovenliggende overlys / installationer
-  Installationskakt
- DT** Angiver dørtелефон
- AN** Angiver altannedøb
- SR** Angiver stigrør
- SV** Angiver vandt/dt slangevinde
-  Primær adgangsvej

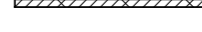
**NOTE:**

Alle mål er i mm.  
 Indretning og målsætning af badekabiner, se bygningsdelstegning.  
 Indretning og målsætning af køkkener, se bygningsdelstegning.

Tegn. nr. **1.182** Rev. **1**

**HAVNEVIGEN**  
 NCC SAGSNAVN: ISTÅRNP  
 NCC SAGSNR.: 29330117  
 BYGHERRE: **NCC** NCC Bolig A/S  
 Østmarken 3B, 2860 Søborg

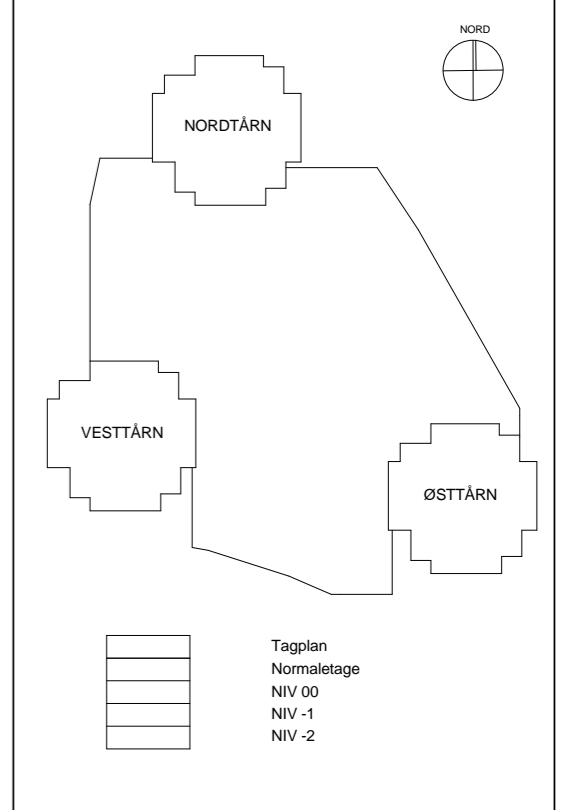

Rev	Rev. dato	Revisionen omfatter	Udf	Kontr
1	23.05.2013	Badekabine B tilrettet, se rev. sky	ESCH	

Emne:  
**NIV 05 - Nordtårn, Type C**  
 Mål: 1 : 100 Sags. nr. 12014  
 Dato: 08.05.2013  
 Udf : ESCH Kontr : JOJ Godk. : JOJ Format : A2  
 Fil : Fase : Hovedprojekt

- NCC** TOTALENTREPRENØR  
 NCC Construction Danmark A/S  
 Østmarken 3B, 2860 Søborg
- ARKITEKT ARKITEMA ARCHITECTS
  - LAND.ARKITEKT SCHÖNHERR A/S
  - KONSTRUKTION NCC Construction Danmark A/S
  - VVS-INSTAL. NCC Construction Danmark A/S
  - EL-INSTAL. NCC Construction Danmark A/S